

OWNER'S MANUAL

REV. A OKT 2009

HAF HELMET AIR FILTER

IMPORTANT WARNING FOR SAFER BLAST CLEANING

1. Use protective equipment: Abrasive-resistant clothing, safety shoes, leather gloves, ear protection, CE-approved air-fed helmet. Air for helmet must be supplied by a breathing air compressor or through a helmet air filter.
2. Check for possible silicosis hazards. Avoid dust.
3. Do not blast with damaged or worn equipment.
4. Point nozzle only at area being cleaned.
5. Use only proper dry and well-screened abrasives specifically intended for blasting.
6. Keep unprotected workers out of the blast area.
7. Before blasting:
 - Check fittings and hose for wear.
 - Safety-wire couplings together.
 - Check helmet filters and air supply.
 - Check pop-up valve for alignment.
 - Test remote controls.
 - Make sure blast machine is adequately grounded.
8. Do not weld on blast machine, this voids approval.
9. Do not substitute Airblast parts or modified equipment in any way.

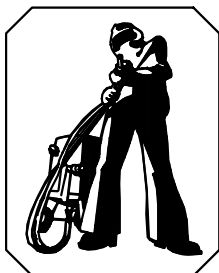

AIRBLAST B.V.

P.O. Box 1075
1700 BB Heerhugowaard
The Netherlands
Tel. : +31-72-5718002
Fax : +31-72-5714340
E-mail : info@airblast.com
Web : www.airblast.com

1.0 INTRODUCTION.

Airblast Helmet Air Filter are designed to remove oil mist, water vapour and particulates down to 0.5 micron from breathing grade compressed air. The Airblast Breathing Air Filter meets OSHA regulation 1910.94 (6) (ii), requiring a trap and carbon filter be installed and regularly maintained to remove objectionable odours, as well as water, oil mist and other particulates. The Airblast Helmet Air Filter is supplied incl. a pressure reducing valve to reduce the pressure to the requirements of supplied air respirators, providing that the inlet pressure does not exceed 8,6 bar (125 PSI).

The Airblast Helmet Air Filter will not remove carbon monoxide and other toxic gases from the airline. Monitors or suitable filters are available.

IMPORTANT

Do not connect the Airblast Helmet Air Filter to bottled air that does not have a pressure reducing valve that will reduce the air pressure to a maximum of 8,6 bar (125 PSI). Failure to comply with this warning could cause the Airblast Helmet Air Filter to explode, causing serious injury or death.

WARNINGS

The Airblast Helmet Air Filter should be assembled, operated and maintained by trained and experienced users.

Read all instructions and warnings before assembling and using the Airblast Helmet Air Filter. Failure to adhere to all instructions and warnings could result in serious injury or death.

Do not connect the Airblast Helmet Air Filter to any air source unless you have confirmed that it supplies breathable grade air. Failure to connect the airline filter to the proper air source could result in injury or death.

Do not modify or alter this Airblast Helmet Air Filter. Use only genuine replacement parts. Use of non genuine parts could reduce filtration capabilities.

Do not remove the safety pressure relief valve. Air will be released when pressure in the filter exceeds 8,6 bar (125 PSI).

Air supplied to the Airblast Helmet Air Filter must be at least Grade D quality air as described in the compressed gas association commodity specification G - 7.1 and OSHA regulation 1910. 134 (d).

The Airblast Helmet Air Filter DOES NOT REMOVE CARBON MONOXIDE (CO) OR TOXIC FUMES. Carbon monoxide alarms, monitoring devices or removal devices must be used in conjunction with this Airblast Helmet Air Filter.

Do not use the Airblast Helmet Air Filter if it has been damaged as the filter is a pressure vessel and damage to the vessel could cause fatigue that could result in serious injury or death. Do not attempt to weld the filter unit.

If the Airblast Helmet Air Filter is being used in conjunction with abrasive blasting, do not use abrasives containing free silica. The use of silica sand can cause respiratory diseases that cause death.

Always use NIOSH, CE or AS approved supplied air respirators. The type of supplied air respirator suitable for each application must be determined by your employer.

Always mount the Airblast Helmet Air Filter on a secure level surface or wall.

Moisture must be drained on a regular basis to keep air supply free of moisture.

Do not loosen the bolts on the Airblast Helmet Air Filter lid when the unit is pressurized. All air must be drained from the filter and air supply to the inlet must be shut of completely before performing any work on the Airblast Helmet Air Filter

ASSEMBLY

2.0 BASE MOUNT

The base mount can be attached in two positions, wall mount or floor mount. To connect the base mount align the arrows on the base mount with the arrows on the filter. NOTE: The base mount will only fit in two positions, the arrows must align before locking.

Turn the filter in a clockwise direction and lock into position. You will hear a click when the base is in the final position.

2.1 PRESSURE REGULATOR

To assemble the pressure regulator, thread the pressure gauge into the body and tighten. Connect the quick disconnect coupler and brass cap to the 3/8" tee and thread the 3/8" tee into the top of the pressure regulator and tighten. It is recommended that the regulator assembly is tightened before mounting onto the Airblast Helmet Air Filter. Use thread sealant on all fittings.

Fit the completed regulator assembly onto the top of the Airblast Helmet Air Filter lid. Once the regulator assembly has been tightened into position you can fit the pressure relief valve and tighten.

!WARNING! The pressure relief valve must be connected to protect the Airblast Helmet Air Filter from over pressurizing.

2.2 INLET CONNECTION

The Airblast Helmet Air Filter has a 1" NPT inlet. It is advised to connect a ball valve close to the inlet so the unit can be shut off for servicing. Connect inlet fittings and tighten. Once the Airblast Helmet Air Filter is completely assembled and connected to compressed air open supply line and check fitting for any air leaks, tighten accordingly.

!WARNING! Do not over tighten fittings, as over tightening could crack the filter casting.

2.4 SIX OUTLET MANIFOLD

To assemble the Six Outlet Manifold, firstly thread the Pressure Gauge (4303000) into the Outlet Manifold for 6 users (4309000) and tighten. Thread all six Couplers (2174200) into the Manifold and tighten. Thread the completed Six Outlet Manifold in to filter lid and tighten. Thread the Pressure Relief Valve (4306000) into the lid and tighten.

!WARNING! The pressure relief valve must be connected to protect the Airblast Helmet Air Filter from over pressurizing.

2.5 HIGH FLOW REGULATOR ASSEMBLY

Thread the High Flow Pressure Gauge (4305000) and 1" NPT Connector (2225500) into the High Flow Regulator (4304000) and tighten. Now thread the completed Regulator into the input port on the body of the Airblast Helmet Air Filter Unit and tighten.

Check ALL fittings and connections are tight. Your filter is now ready to use.

Note:

If the pressure gauge on the High Flow Regulator and the pressure gauge on the Manifold are reading more than 0,7 bar (10 PSI) apart, your cartridge is blocked and needs replacing.

Refer to your respirator instruction manual for pressure ranges for your respirators, increase the pressure according to the number of operators.

OPERATION

3.0 AIR PRESSURE

The air pressure supplied to the Airblast Helmet Air Filter should not exceed 8,6 bar (125 PSI). When setting the outlet pressure using the pressure regulator refer to your respirator instruction manual to set the correct air pressure.

3.1 AIR TEMPERATURE

The air supplied to the Airblast Helmet Air Filter should not exceed 60° C. (140° F.). Do not connect the Airblast Helmet Air Filter directly to the compressor outlet manifold.

3.2 AIR QUALITY

The Airblast Helmet Air Filter does not remove carbon monoxide and other toxic gases from the breathing air supply. A monoxide monitor must be used at all times. Supplied air passing through this Airblast Helmet Air Filter must meet the requirements of Grade D. EN12021 or ASMZS 1715 refer to your relevant authorities for copies of these standards. Regular tests of the compressed air must be carried out to ensure it meets the requirements for breathable air.

3.3 AIR CONNECTIONS

Connect air fittings that meet the requirements of OSHA for respirable air. The inlet thread size is 1" NPT. All connections should be sealed using liquid thread sealant. If the Airblast Helmet Air Filter is hard piped an isolation ball valve must be used to enable depressurization for servicing.

MAINTENANCE

4.0 FILTER CARTRIDGE

The filter cartridge should be inspected weekly or more often depending on usage and the conditions of the air system in which the Airblast Helmet Air Filter is installed. The filter cartridge should be replaced after a period of 3 months based on a 40 hrs. week. The filter cartridge must be replaced immediately if the following exist:

- The presence of odour and or tastes in the air being supplied to the respirator.
- Presence of moisture at the outlet fittings.
- Large pressure drop across the filter.

REPLACING FILTER CARTRIDGE

1. Shut off the air supply to the Airblast Helmet Air Filter and drain all air from the body by opening the drain tap.
2. Remove the bolts from the lid and separate the lid from the body.
3. Remove the cartridge and dispose in an appropriate disposal area.
4. Clean the inside of the filter body to remove any contaminants, do not clean with volatile chemicals.
5. Insert a new filter cartridge and reassemble the lid, tighten the bolts in the pattern drawn in tighten to 7,37 Nm (10ft./lbs.) torque. Tighten the bolts cross wise.
6. Record the date on the sticker supplied with the filter cartridge and place on to the Airblast Helmet Air Filter.

4.1 DRAINING MOISTURE

Water will accumulate in the filter tank, this should be drained by opening the ball valve. This should be done each day. In very humid climates or if there is large amounts of water in the air supply it is recommended to leave the ball valve partially open to drain the moisture.

Optional for wall mount execution: auto drain assembly. When fitted with auto drain assembly moisture will automatically drain from the unit as required. It is recommended that the auto drain is rinsed in water to keep clean and free of particles which could cause blockages.

4.2 LID BOLTS AND O-RINGS

The Airblast Helmet Air Filter lid bolts should be checked to ensure that they are tight.

The recommended tightness for the lid bolts is 7,37 Nm (10ft./lbs.). Check the lid bolts and o-rings and replace if damaged.

HAF HELMET AIR FILTER

AIBLAST HELMET AIR FILTERS

ITEM	ART NR	MODEL	DESCRIPTION
01.	4300000	HAF-I	Helmet Air Filter for 1 or 2 users
02.	4320000	HAF-II	Helmet Air Filter for 1-6 users

SPARE PARTS

ITEM	ART NR	DESCRIPTION
01.	4301000	3/8" Tee - brass
02.	4302000	3/8" Pressure regulator
03.	4303000	Pressure gauge
04.	4304000	3/8" Pressure regulator – high flow
05.	4305000	Pressure gauge – high flow
06.	4306000	Pressure relief valve
07.	4307000	Filter cover for 1 or 2 users HAF
08.	4308000	Filter cover for 1-6 users HAF
09.	4309000	Outlet manifold for 1-6 users
10.	4310000	Filter housing
11.	4311000	O-ring (set of 2)
12.	4312000	Bolt (set of 4)
13.	4313000	Base mount
14.	2175200	CCC-38/I Quick coupling 1 or 2 users
15.	2174200	CCC-38/O Quick coupling for 1-6 users
16.	2225500	Hex nipple 1"
17.	4250401	Filter cartridge for HAF
18.	2170400	KAG-10 Quick coupling 1"outer thread
19.	4316000	Drain valve - brass

See drawing next page.

6-outlet top view

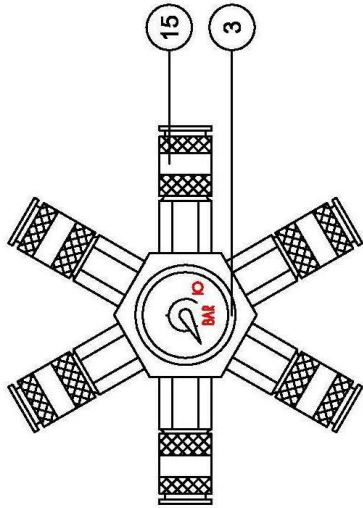

6-outlet side view

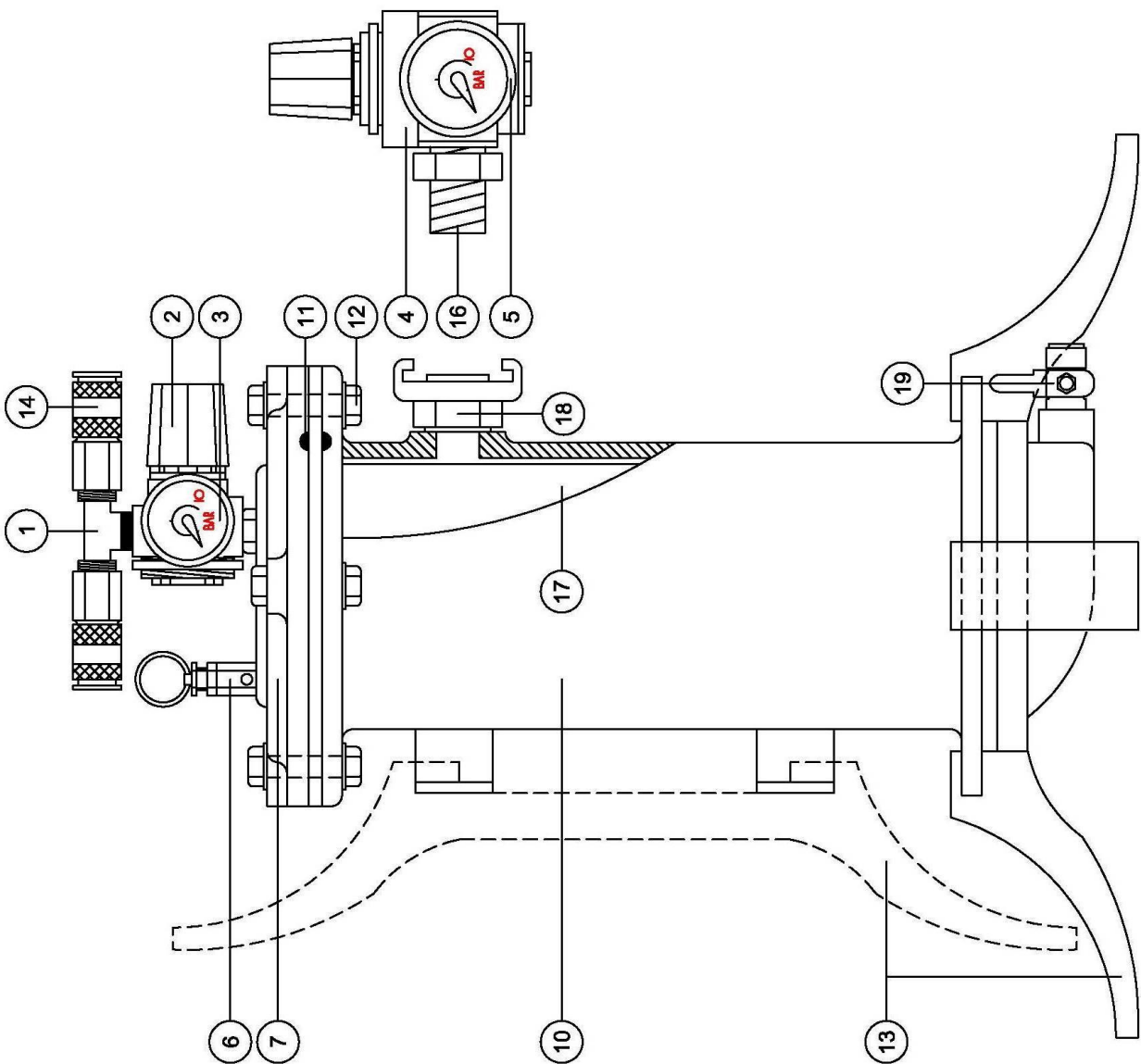
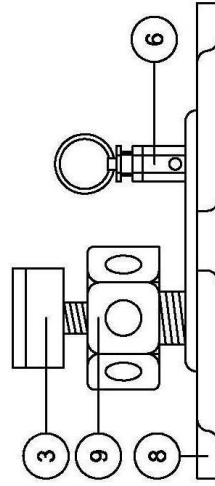

Airblast Group

Airblast B.V.

P.O. Box 1075
1700 BB Heerhugowaard
The Netherlands
Tel : +31 72 5718002
Fax : +31 72 5714340
Email : info@airblast.com
Web : www.airblast.com

Airblast Middle East L.L.C.

P.O. Box 33419
Dubai
United Arab Emirates
Tel : +971 4 3242776
Fax : +971 4 3242778
Email : airblast@emirates.net.ae

Airblast Saudi Trading & Industrial Est.

P.O. Box 30476
Al-Khobar 31952
Kingdom of Saudi Arabia
Tel : +966 3 8473178
Fax : +966 3 8471430
Email : info@airblast.com.sa

Airblast Qatar WLL

P.O. Box 47044
Wakra
Qatar
Tel : +974 4 4631043 / +974 4 4631074
Fax : +974 4 4631154
Email : info@airblast.com.qa

Asia Airblast Pte Ltd.

58, Tuas Basin Link
Singapore 638774
Tel. : +65 6266 6010
Fax : +65 6266 6968
E-mail : airblastsg@singnet.com.sg

AB Corrosion Control Equipment Sdn Bhd

No. 33, Jalan Permas 3/18
Bandar Baru Permas Jaya
81750 Masai, Johor Darul Takzim
Malaysia
Tel : +60 7357 7989
Fax : +60 7357 7689
Email : airblastmy@airblastasia.org

Airblast Equipment India Private Ltd.

#6-1-73/Unit - 207 'SAEED PLAZA'
HDFC Bank Building
Lakdi Ka Pul
Hyderabad 500004-AP
India
Tel : +91 40 6674 8855
Fax : +91 40 6674 8851
Email : info@airblastindia.com